



power-heat-set

The perfect solution for every customer

OPERATOR TOOLS CATALOGUE 2025

Operator Tools for GVA and HiPerSet

With this catalogue we are offering a great variety of operator tools for our GVA and HiPerSet machines to make the operators' work easier: From handy devices to personal protective gear.

Yarn Separator.....	4
Splice Station.....	4
Yarn Pulling Aid	4
Threading Aid.....	5
Yarn Clamping Unit	5
Yarn Comb.....	5
Yarn Clamps.....	5
Splice Set for Power-Heat-Set Creel Version 2	6
Devices & Tools	8
Keypads & Controls for Inverters.....	10
Polishing Tools.....	11
Calibration Tools.....	11
Helpful Items.....	12
Cleaning Tools	13
Personal Protective Gear	13

The perfect solution for every customer

40 years of experience- more than 1.000 machines in the heatsetting market: This is Power-Heat-Set. Our GVA and HiPerSet machines offer a wide variety of products to fit your specific needs.

All our equipment is manufactured by highly qualified technicians at our German based head-quarters constantly improving quality, operability, productivity, sustainability and handling to provide innovative technology and customized solutions.



Consulting

Analyzing your specific needs, planning customized machine layouts, consulting you on process optimizations or financing... Whatever you need, we are happy to offer a comprehensive carefree package for you.



Worldwide Support

Our consultants and service technicians operate worldwide to ensure the best possible long-term support for your production and equipment, from machine building and installation to maintenance and operation.



Tech. Online Support

We are not only your machine and spare parts supplier, but we are also your best source for technical support. Our technical support is available to you by phone or e-mail for any questions and problems.



24/7 Support Hotline

Excellence in customer service is of paramount importance to us. Consequently we have established a service hotline which is available 24 hours a day, seven days a week.



Repair & Refurbishment

To reduce downtime and costs, we offer a special exchange and repair program. Simply send in your broken machine part and we'll take care. In some cases, we offer refurbished machine parts in an exchange program.



OEM Spare Parts

We have a wide range of spare parts in stock with a high availability for standard machines. Our OEM parts have been developed exclusively for our machines and customers and thus are specially fitted to your needs.

Do you have questions or would you like to order?
Don't hesitate to contact us!

Phone: +49 86 31 / 393 - 480

E-Mail: order@power-heat-set.com



Yarn Separator

With this handy yarn separator the individual ends are guided via the ceramic eyelets of the winder making threading considerably easier as the yarn separator eliminates the need to separate the yarn by hand. Consequently, the yarn separator reduces the risk of yarn breakage which is particularly advantageous when used at the winder.

Yarn Separator
Art. No. 105967



Yarn Pulling Aid

This light and handy yarn pulling aid enables an easy threading of the individual ends through the separate eyelet discs at several points in the machine.

Yarn Pulling Aid
Art. No. 105968

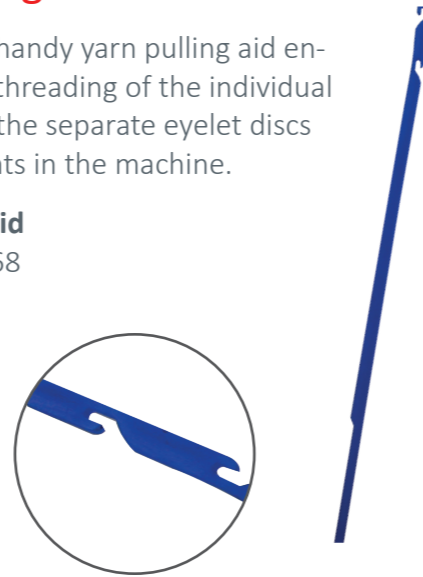

Splice Station

The yarn combs or yarn clamps are clipped on to the splice station from the right side and the ends of the winder are fixed to the splice station from the left side. In this way the ends of both sides are not only perfectly separated and fixed at the splice station but are also crossed over.

Due to the perfect separation and by using the pedal the yarn can be spliced in an extremely short time and mostly automatically in the correct sequence.

Additional note: This version can currently be used for splicing up to 36 ends. Upon request we can develop it for the use of more ends as well.

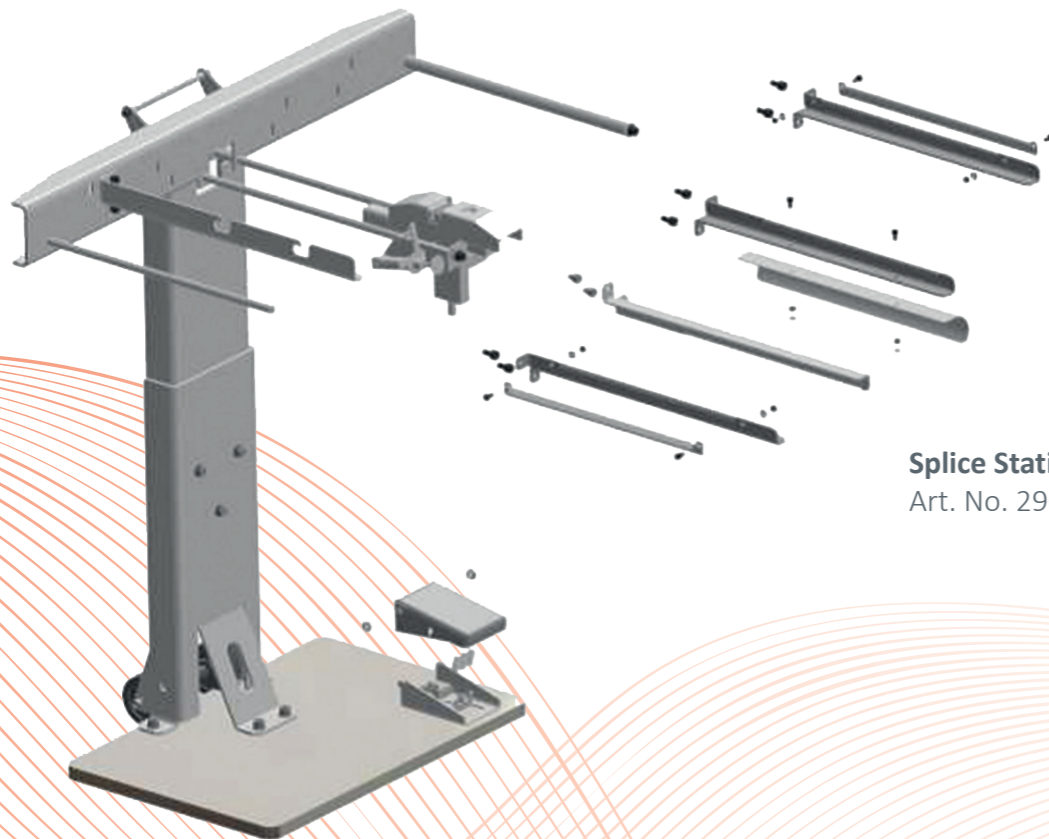

Splice Station
Art. No. 290294

Threading Aid

This tool helps you with the threading at several points at the machine. The operator can clamp up to 96 ends and doesn't have to hold each and every end which makes the threading at the creel, false twist or winder much easier.

Threading Aid
Art. No. 105978



Yarn Clamping Unit

In combination with the threading aid, you can quickly splice the individual ends with this single yarn clamping unit as the threading aid and the yarn clamps are holding the yarn for the operator.

Yarn Clamping Unit
Art. No. 118005028004419

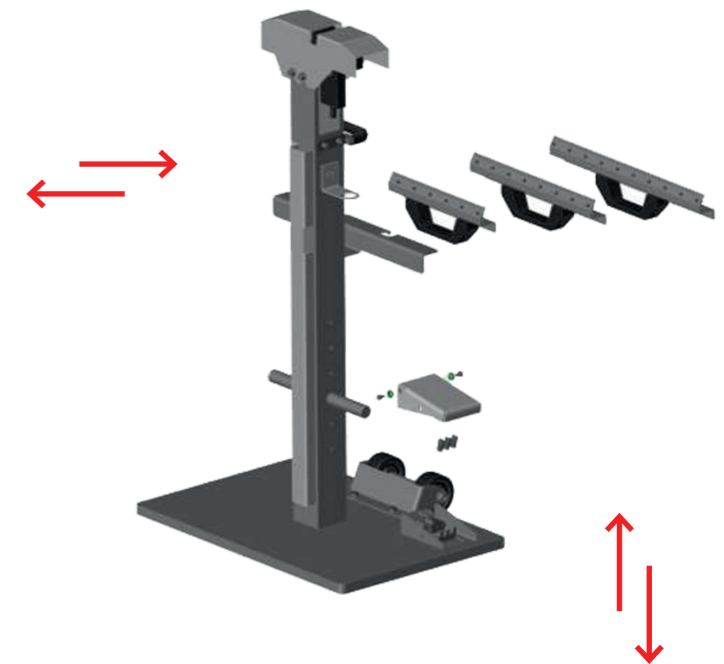

Yarn Comb

With this comb, you can quickly thread from the accumulator to the splicing station or clamping unit. You can extend this 48-ends comb to up to 96 ends.



Machine	No. of ends	Art. No.
GVA	8 ends	105572
	12 ends	118005028005377
	16 ends	105084
HiPerSet	24/48 ends	118005028005415
	30/60 ends	118005028005409
	36/72 ends	118005028005407
	42/84 ends	118005028005383

Yarn Clamps

The operator will be able to separate each and every end at the belt exit and perfectly fix the ends in parallel lines via our yarn clamp. In this way the work needed at our accumulator or winder will be sufficiently reduced.

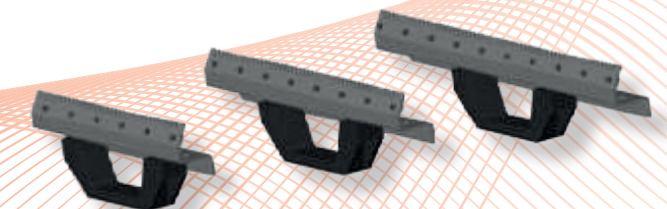

No. of ends	Art. No.
36 ends cpl	118005028004424
48 ends cpl	118005028004420
60 ends cpl	118005028004433

Splice Set for Power-Heat-Set Creel Version 2

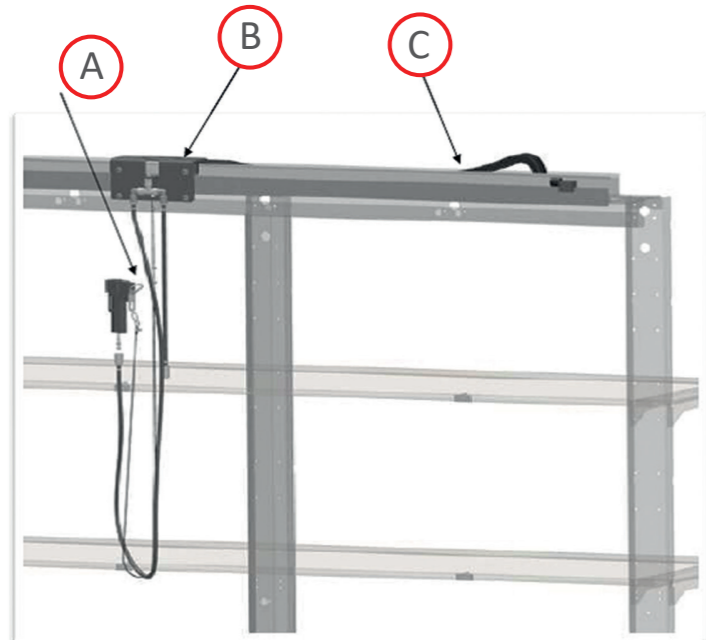

Splice Set Complete Art. No. 105952

In addition, we are offering the matching Splice Set for our creel, including the corresponding attachments and single components comprising:

- A) Connecting cable with splicer
- B) Carriage
- C) Guide

Additional note: Upon request we can develop it for other creels as well.

A) Connecting Cable with Splicer

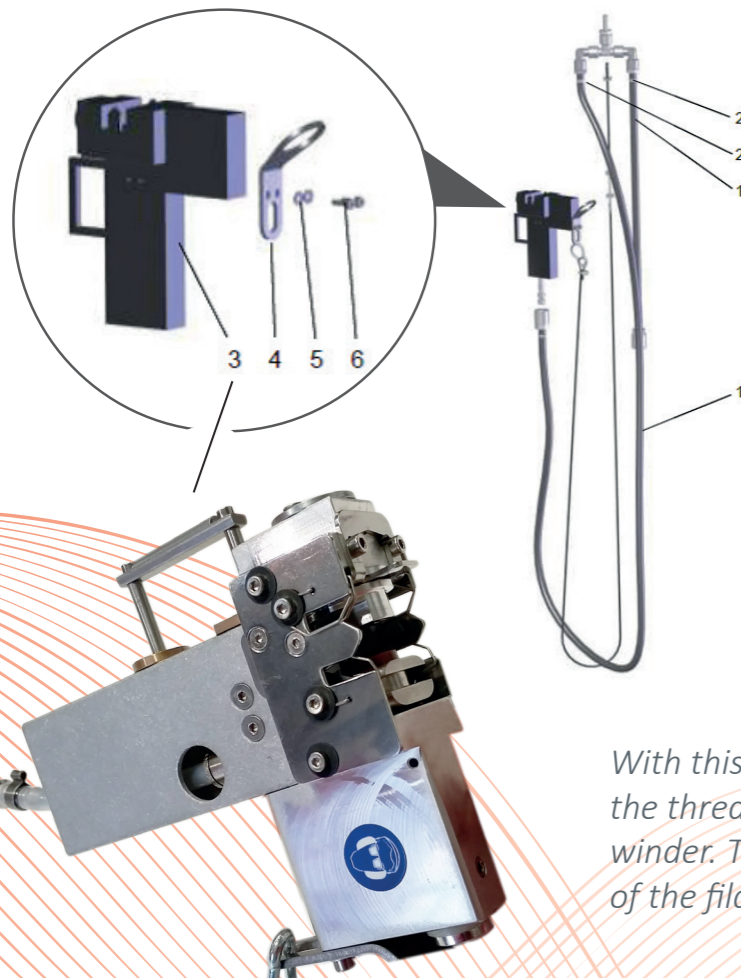

- 1 **Fabric-hose with filling, Ø 8/14**
Art. No. 105715 (by meter)
- 2 **Hose clamp 12-20**
Art. No. 105716
- 3 **Hand splicer**
Art. No. 102446
- 4 **Suspension plate**
Art. No. 105717
- 5 **Washer A4,3**
Art. No. 102169
- 6 **Hexagon socket screw M4x12**
Art. No. 103801

With this high quality hand splicer you can splice the threads directly at the bobbin creel or at the winder. This type of splicer works with entangling of the filaments instead of making a knot.

B) Carriage

- 1 **Carriage complete**
Art. No. 105952
- 2 **Hexagon socket screw**
Art. No. 103295
- 3 **Spacer washer**
Art. No. 105456
- 4 **Roller**
Art. No. 105434
- 5 **Ball bearing**
Art. No. 105435
- 6 **Retaining ring**
Art. No. 105458
- 7 **Spacer**
Art. No. 105457
- 8 **Washer**
Art. No. 100194
- 9 **Hexagon head nut**
Art. No. 103658

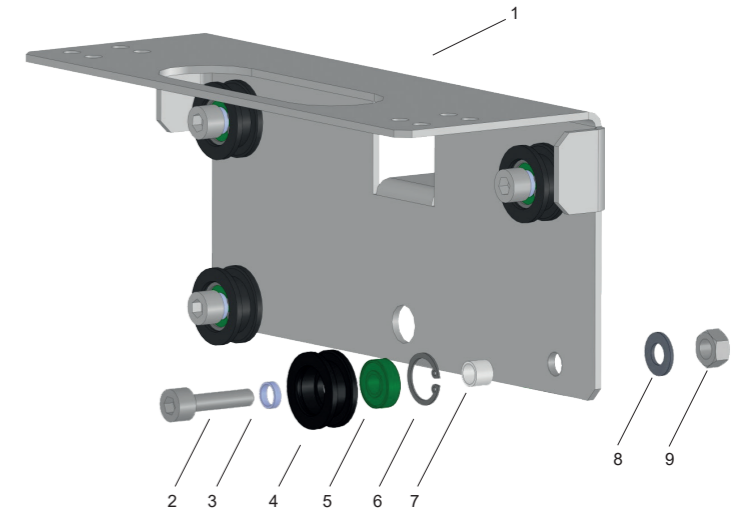

C) Guide



- 1 **Bracket cable chain**
Art. No. 110232009100070
- 2 **Hexagon cap nut M6**
Art. No. 104981
- 3 **Washer A6,4**
Art. No. 101979
- 4 **Hexagon screw M6 x 12**
Art. No. 900933000000056
- 5 **Rubber-metal buffer 25x28 D**
Art. No. 105256
- 6 **End stop**
Art. No. 105656
- 7 **Set screw M8 x 16**
Art. No. 900913000000044
- 8 **Energy chain (per meter)***
Art. No. 105257

*Length of energy chain and compressed air supply

Machine Type	No. of ends	Energy chain	Compressed air hose Ø 8/14
GVA	72/60 ends	2x 5,1 m	2x 8,5 m
	48/36 ends	2x 3,3 m	2x 6,5 m
HiPerSet	36 ends	5,1 m	8,5 m
	48 ends	6,8 m	10 m
	60 ends	8,5 m	12 m
HiPerSet two side left and right Art.	48 ends	2x 3,3 m	2x 6,5 m
	60 ends	2x 4,5 m	2x 7,5 m

Devices & Tools

HiPerSet Conveyor Belt Installation Aid
Art. No. 105378

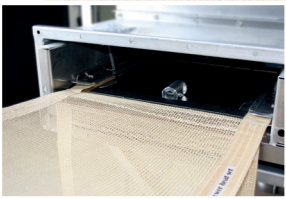

Additional note: Upon request we can develop it for GVA conveyor belts as well.

Tension Meter
Art. No. 104584

Offers an excellent reading accuracy of the measurement results. A further special feature is the analogue display, which quickly shows tensile stress changes and fluctuations and enables optimum process settings.



Speedometer
Art. No. 106152

Measures the speed of rotating parts and can be used for our conveyor belts, belts and motors.



Conveyor Belt Fixing Kit
Art. No. 103940



Devices & Tools

GVA Conveyor Belt Installation Aid
Art. No. 106074



PT100 Installation Wrench
Art. No. 105964



Ensures a damage free installation / deinstallation of the PT 100 Sensors.

Hook Wrench
Art. No. 105966



Allows the springs of the drum motor and the belt pressure rolls to be securely attached and detached.

Chamber Key
Art. No. 105965

Helps to tighten the chamber trapezium between the chambers.

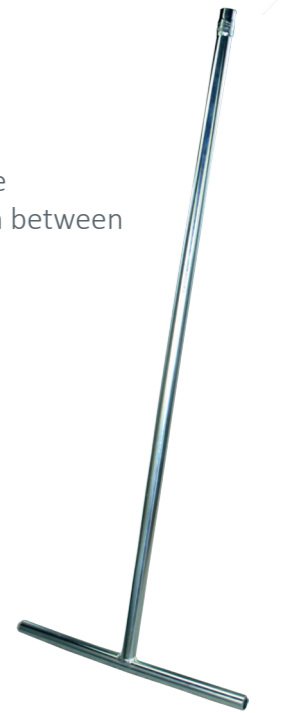

Keypads & Controls for Inverters



Keypad for i550 Series
Art. No. 87706300000048



Keypad for 8400 Series
Art. No. 601304



Case with extension cable for 8400 series
On request



Keypad for 1000 Series
Art. No. 601387



Keypad for 8200 series
Art. No. 105799



Keypad TwinAccu V2 inverters
Art. No. 105834

The different keypads enable the operators to remotely define parameters, display and transfer process data to other basic devices as well as to control specific machine parts (e.g. lock and unlock).



TRB and Steam Channel Polishing Tools

For removing scratches from the steam channel and to avoid yarn hangers by ensuring a smooth surface.



Abrasive Paper Holder
Art. No. 106065



Abrasive Paper Strips
Art. No. 106066 for 106065



Abrasive File
Art. No. 106067

Calibration Tools



Steam Valve Calibration Device
Art. No. 601191

Supports a smooth initialization of the intelligent positioning controller.



PT100 Calibration Tool
Art. No. 104642

Ensures an exact measurement of the temperature by adapting the differences of the resistances in the lines.

Helpful Tools



Endoscope
Art. No. 820024
Handy and practical device for inspection.



Yarn Scissors
Art. No. 105969

Clipboard
Art. No. 100338



Ring Finger Scissors
Art. No. 105970

Hand Yarn Cutter
Art. No. 820018



Ring Yarn Cutter
Art. No. 820017



Cleaning Tools



Detergent
Art. No. 103673

The perfect cleaning solution for every job. This cleaning detergent is used to clean the interior of the chamber.



Compressed Air Blow Gun
Art. No. 105971

Helps cleaning the creel and yarn brakes from dirt caused by the yarn production.

Personal Protective Gear

Your safety is our priority. Therefore, we offer a selection of protective items.



Protection Glasses
Art. No. 105974



Ear Protection
Art. No. 105973



Disposable Suit
Art. No. 105972



Face Mask
Art. No. 105976



Working Apron
Art. No. 105977



Cleaning Gloves
Art. No. 105975



power-heat-set

Power-Heat-Set GmbH

Amperstraße 4

84513 Toeing am Inn

GERMANY

Phone: +49 (0) 8631 393-480

Fax: +49 (0) 8631 393-580

E-Mail: mail@power-heat-set.com

Internet: www.power-heat-set.com

GERMAN 
Technology

